

PRODUCT No. 6589

Fixed instrumental wheel – 160 mm



(Illustration photograph)

Technical data

Material	Galvanized-steel/Aluminium/PU
Type	Fixed
Bearing	Ball bearing
Weight	1,8 kg
Load capacity (Dynamic/static)	800 / 1600 kg
Temperature resistance	-20/+60°C
Thread width	50 mm
Wheel diameter	160 mm
Plate holes centres	80/75 x 105 mm
Plate size	137 x 105 mm
Height (total)	200 mm
Plate hole diameter	11 mm

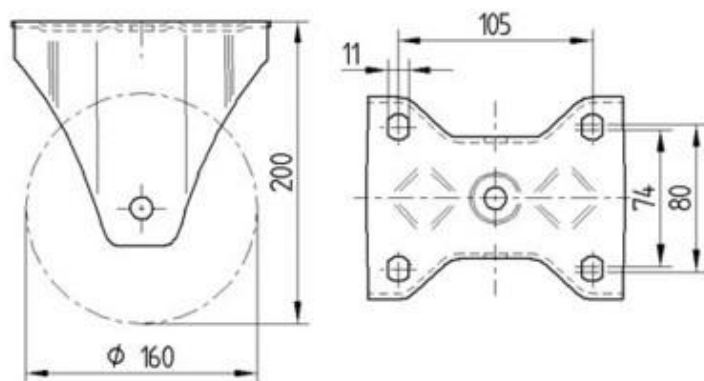

Attributes

- Made of pressed galvanized steel – forks. Wheel is made of polyurethane with aluminium center.
- Reinforced steel fork in galvanized surface finishing.
- Wide usage possibility with wide range of equipment, where mobility is needed (smooth and sturdy surfaces only).
- In accordance with EN 12532 regulation – Pulleys and wheels for speeds up to 4 km/h.

Product purpose

- Designed as instrumental wheel.

Additions

- Offered as – fixed, turnable and turnable with brake types.
- Offered in different sizes - with 160 mm to 250 mm wheel diameter.