

PRODUCT No. 7950

Underground monolithic tank for rainwater – 4000 l



(Illustrative photograph)

Technical data

Material	Polyethylene (PE-LLD)
Capacity	4000 l
Weight	175 kg
Max. covering by soil	1000 mm
Width	2420 mm
Depth	1500 mm
Height	2050 mm

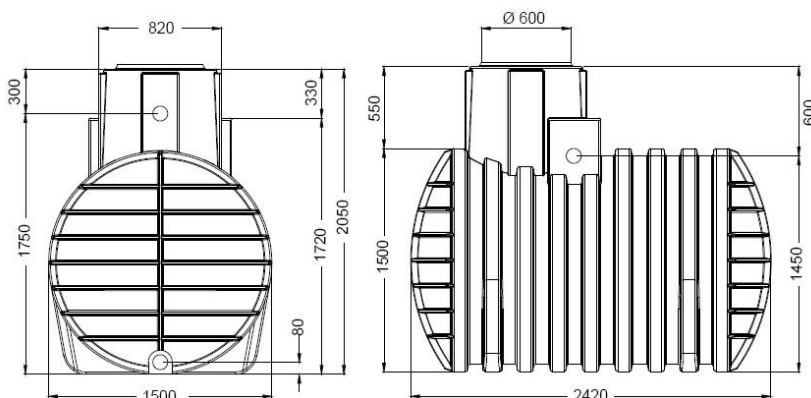

Attributes

- Robust self-supporting construction made of one piece.
- Construction settles on the paved surface without need for concreting.
- Provided with integrated technological holes in the shaft space.
- Holes for water intake, connection to another tank or overflow.
- Seals are included.
- In the shaft part is preparation for mounting the built-in self-cleaning filter.
- Shaft cover with child lock to prevent easy or accidental opening.
- Provided with a warranty period of 10 years.

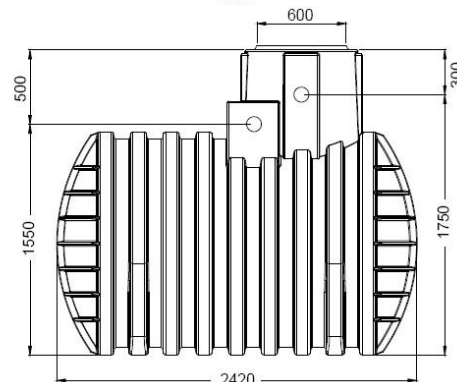

Color variations

- Black.

Product purpose

- Designed for underground installation for rainwater collection.