

PRODUCT No. 8081

Underground Compact tank for rainwater – 1600 l



(Illustrative photograph)

Technical data

Material	Polyethylene
Capacity	1600 l
Weight	65 kg
Width	2100 mm
Depth	1050 mm
Tank height	1180 mm
Max. height of shaft	780 mm

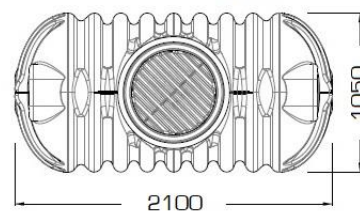
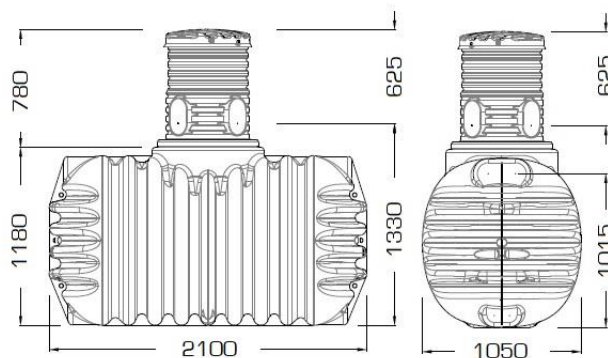

Attributes

- Made of 100 % recyclable polyethylene.
- Compact shape of the tank, easy and economical installation.
- Integrated dome shaft with possibility of frost-resistance installation underground.
- The shaft can be rotated in 360° for variable and easy installation.
- Connection openings are equipped with fitting.
- Equipped with cover with child lock.
- Provided with a warranty period of 15 years.

Color variations

- Black.

Product purpose

- Designed for underground installation for rainwater collection.