

Plastic container with flat lid and opening – 1100 l
TYPE: 0026-3/8-B

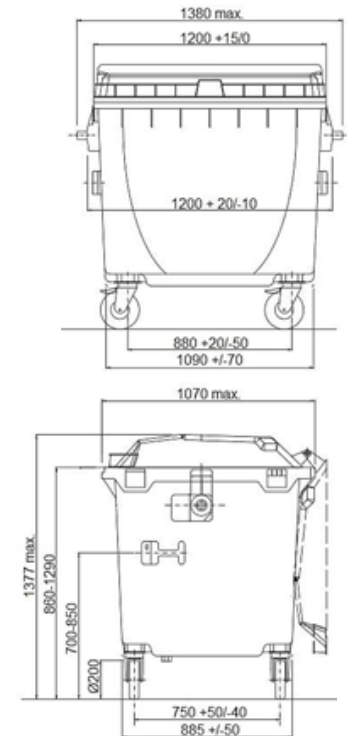

Illustrational photograph



TECHNICAL DATA

Material	Plastic (HDPE)
Capacity	1100 l
Weight	46,5 kg (± 5 %)
Max. weight	510 kg (± 5 %)
Load capacity	440 kg (± 5 %)
Wheel diameter	200 mm
Dimensions (W x D x H)	1380 x 1070 x 1377 mm

ATTRIBUTES

- Made of 100 % recyclable plastic high-density polyethylene (HDPE).
- Equipped with opening modified for separated waste – circular (160-190 mm).
- Standardly delivered with four wheels with 200 mm diameter – 2x swivel, 2x swivel with brake.
- Manufactured in accordance of EN 840 regulation and certified according to RAL-GZ 951/1.
- Resistant to UV radiation, chemical and biological impacts or to frost.
- Smooth surfaces help against sticking of waste on them.
- Production materials does not contain any cadmium and can be granulated again.
- Version without lid lock.

COLOUR VARIATIONS

Body / lid – black / grey (for metals).

PRODUCT PURPOSE

Product is designed as collection container for municipal waste separation – modified for collection of metals.

ADDITIONS

Not suitable for storing hot ash.
 Can be delivered in version with central brake.